

CONSTRUCTION SEQUENCE

- EXCAVATE FOR LEVEL BASE TO A LENGTH ADEQUATE FOR WIDTH OF THE REINFORCED MASS AND DRAINAGE SYSTEM AS REQUIRED BY SITE CONDITIONS AT BACK OF REINFORCED MASS.
- COMPACT FOUNDATION TO 95% STANDARD PROCTOR (ASTM D689).

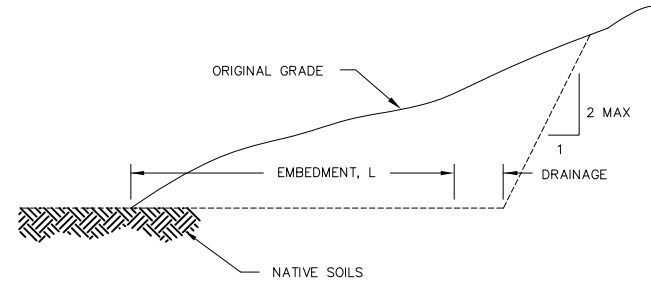

STEP 1

- INSTALL FIRST LAYER OF MIRAGRID WITH ROLL DIRECTION PERPENDICULAR TO SLOPE/WALL FACE.
- PULL MIRAGRID TIGHT, KEEP TENSION APPLIED UNTIL BACKFILL IS PLACED, STAPLES OR STAKES MAY BE USED TO MAINTAIN TENSION.

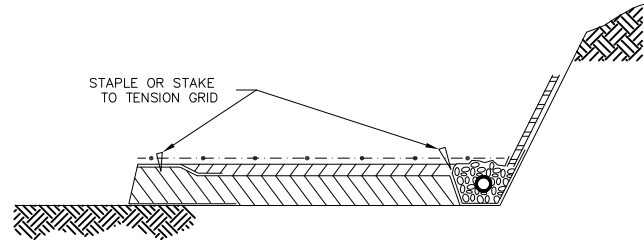

STEP 4

- CHECK LEVEL OF BASE.
- CHECK ALL LINE, GRADE, AND CURVES.
- PLACE PLYWOOD FORM AT FRONT OF REINFORCED MASS AND DRAPE MIRAFI 160N OR FW404 SOIL RETENTION FABRIC OVER FORMWORK.
- PLACE BACKFILL IN MAXIMUM LIFTS OF 9 INCHES, AND COMPACT TO 95% OF STANDARD PROCTOR. ALLOW ROOM FOR CRUSHED STONE DRAINAGE BED AT THE BACK OF THE REINFORCED MASS.

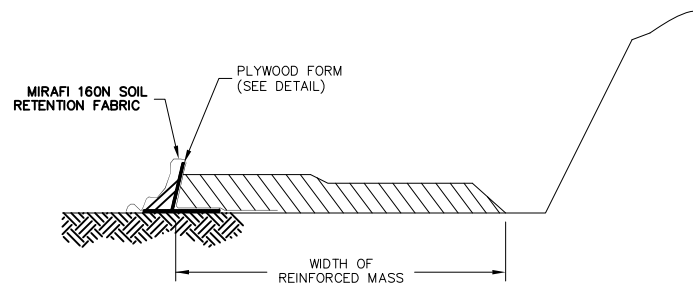

STEP 2

- PLACE NEXT COURSE REPEATING STEPS 2 AND 3.
- PLACE ADDITIONAL GRID BY REPEATING STEPS 4. (SEE PLAN & PROFILE DRAWINGS FOR ELEVATIONS AND EMBEDMENT LENGTHS)

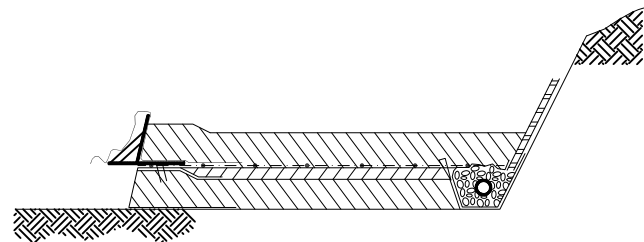

STEP 5

- PLACE MIRADRAIN G200N DRAINAGE COMPOSITE, 140N FILTER FABRIC, CRUSHED STONE, AND DRAINAGE COLLECTION PIPE.
- WRAP MIRAFI 160N OR FW404 OVER COMPACTED FILL AND REMOVE FORM.
- PLACE FILL ABOVE UPPER SOIL WRAP PORTION AND LEVEL.
- REPEAT ABOVE STEPS UNTIL ADDITIONAL PRIMARY REINFORCEMENT IS REQUIRED.

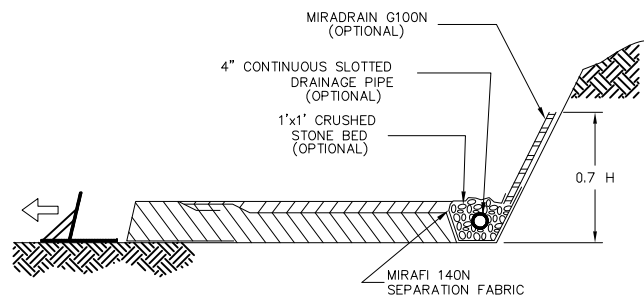

STEP 3

- REPEAT STEPS 2 THRU 4 UNTIL SLOPE IS AT REQUIRED HEIGHT.
- PLACE FINAL BACKFILL AND TOPSOIL.

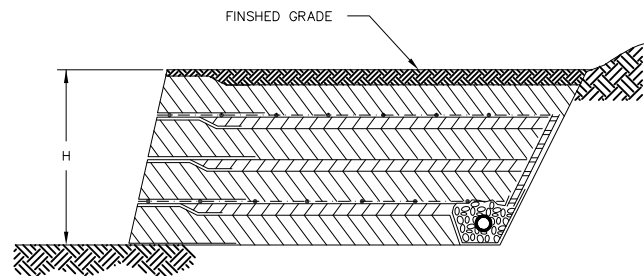

STEP 6

CONSTRUCTION NOTES FOR MIRAGRID AND BACKFILL SOILS PLACEMENT WITHIN THE GEOSYNTHETICALLY REINFORCED RETAINING WALL

- 1.0 DESIGN PARAMETERS
- 1.1 DESIGN OF THE REINFORCED SOIL STRUCTURES ARE BASED UPON THE FOLLOWING PARAMETERS:
- | BACKFILL SOILS | FRICITION ANGLE | COHESION | MOIST UNIT WEIGHT |
|---------------------|-----------------|----------|-------------------|
| NATIVE (SITE) SOILS | 32° | 0 psf | 130 pcf |
| | 27° | 0 psf | 125 pcf |
- 1.2 MINIMUM FACTOR OF SAFETY
- | | |
|------------------------|---------|
| EXTERNAL | |
| SLIDING | = 1.5 |
| OVERTURNING | = 2.0 |
| BEARING | = 2.0 |
| INTERNAL | |
| RUPTURE | = 1.5 |
| PULLOUT | = 1.5 |
| GLOBAL | = 1.3 |
| 1.3 UNIFORM SURCHARGE | 250 psf |
| 1.4 HYDROSTATIC FORCES | NONE |
| 1.5 SEISMIC FORCES | NONE |
- 2.0 MATERIALS
- 2.1 REINFORCED BACKFILL SOILS MATERIAL FOR THE REINFORCED STRUCTURES SHALL MEET THE REQUIREMENTS OF THE SPECIFICATION FOR REINFORCED BACKFILL AS DEFINED BY THE HOUSTON LEEVE ROAD SPECIFICATIONS.
- 2.2 GEOGRID REINFORCEMENT SHALL BE MIRAGRID GEOGRID; MANUFACTURED BY THE TENCATE MIRAFI; ATLANTA, GEORGIA.
- 2.3 SOIL RETENTION FABRIC SHALL BE MIRAFI 160N OR FW404; MANUFACTURED BY THE TENCATE MIRAFI; ATLANTA, GEORGIA.

- 3.3 ALL BACKFILL MATERIAL USED IN THE GEOSYNTHETIC REINFORCED STRUCTURE SHALL BE COMPACTED AS REQUIRED IN SECTION 3.1.
- 3.4 AT THE END OF EACH DAY'S OPERATIONS, THE CONTRACTOR SHALL SHAPE THE LAST LIFT OF BACKFILL TO MAINTAIN ADEQUATE DRAINAGE AND PREVENT PONDING.
- 3.5 TESTING METHODS, FREQUENCY AND VERIFICATION OF MATERIAL SPECIFICATIONS AND COMPACTION SHALL BE THE SOLE RESPONSIBILITY OF THE OWNER.
- 4.0 MIRAGRID GEOGRID PLACEMENT
- 4.1 MIRAGRID GEOGRID PLACEMENT SHALL BE PLACED AT THE LOCATIONS AND ELEVATIONS SHOWN ON THE DRAWINGS.
- 4.2 MIRAGRID GEOGRID LENGTH SHALL BE AS SHOWN ON THE CONSTRUCTION DRAWINGS.
- 4.3 PRIOR TO PLACING FILL, THE GEOGRID MATERIALS SHALL BE PLACED TO LAY FLAT AND PULLED TAUT TO REMOVE ANY SLACK IN THE GEOGRID.
- 4.4 TRACKED CONSTRUCTION EQUIPMENT SHALL NOT BE OPERATED DIRECTLY ON THE GEOGRID. A MINIMUM FILL THICKNESS OF 6" IS REQUIRED FOR THE OPERATION OF TRACKED VEHICLES OVER THE GEOGRID. TURNING OF TRACKED VEHICLES SHOULD BE AVOIDED TO PREVENT TRACKS FROM DISPLACING THE FILL AND THE GEOGRID.
- 4.5 RUBBER Tired VEHICLES MAY PASS OVER THE GEOGRID REINFORCEMENT AT SLOW SPEEDS, LESS THAN 10 MPH. SUDDEN BRAKING AND SHARP TURNING SHALL BE AVOIDED.
- 5.0 GEOGRID LAYOUT OR PLACEMENT CHANGES
- 5.1 NO CHANGES TO THE MIRAGRID LAYOUT, INCLUDING, BUT NOT LIMITED TO, LENGTH, GEOGRID STRENGTH (TYPE), OR ELEVATION, SHALL BE MADE WITHOUT THE EXPLICIT WRITTEN CONSENT OF THE PROJECT ENGINEER.
- 6.0 SURFACE DRAINAGE
- 6.1 BACKFILL SHALL BE GRADED AWAY FROM THE SLOPE FACE AND ROLLED AT THE END OF EACH WORK DAY TO PREVENT PONDING OF WATER ON THE SURFACE OF THE REINFORCED SOIL MASS.
- 6.2 SURFACE DRAINAGE AND SITE GRADING SHALL BE THE RESPONSIBILITY OF OTHERS.
- 7.0 SPECIAL PROVISIONS
- 7.1 THE DESIGN PRESENTED HEREIN IS BASED ON SOIL PARAMETERS, FOUNDATION CONDITIONS, GROUNDWATER CONDITIONS, AND LOADINGS STATED IN SECTION 1.0 OF THESE SPECIFICATIONS.
- 7.2 TENCATE ASSUMES NO LIABILITY FOR INTERPRETATION OF SUBSURFACE CONDITIONS SUITABILITY OF SOIL DESIGN PARAMETERS, AND SUBSURFACE GROUNDWATER CONDITIONS.
- 7.3 THE OWNER OR OWNERS REPRESENTATIVE IS RESPONSIBLE FOR REVIEWING AND VERIFYING THAT THE ACTUAL SITE CONDITIONS ARE AS DESCRIBED IN SECTION 1.0 PRIOR TO AND DURING CONSTRUCTION.
- 7.4 ALL PLAN DIMENSIONS MUST BE VERIFIED BY THE CONTRACTOR. THE PROJECT ENGINEER MUST BE NOTIFIED OF ANY DISCREPANCIES BEFORE THE CONTRACTOR BEGINS WITH WORK.

- 3.0 TECHNICAL REQUIREMENTS
- 3.1 THE FOUNDATION FOR THE STRUCTURE SHALL BE GRADED LEVEL FOR A WIDTH EQUAL TO OR EXCEEDING THE APPROVED LENGTH OF THE REINFORCING GRIDS OR AS SHOWN IN THESE CONSTRUCTION PLANS. PRIOR TO SLOPE CONSTRUCTION, THE FOUNDATION SHALL BE COMPACTED TO 95% STANDARD PROCTOR DENSITY AS DETERMINED BY ASTM D698 AT 1% DRY TO 3% WET OF OPTIMUM MOISTURE CONTENT. ANY FOUNDATION SOILS FOUND TO BE UNSUITABLE SHALL BE REMOVED AND REPLACED.
- 3.2 AT EACH REINFORCEMENT ELEVATION, BACKFILL AREA SHALL BE LEVEL BEFORE PLACING THE REINFORCEMENT. THE REINFORCEMENT SHALL BE PLACED NORMAL TO THE FACE OF THE WALL. EACH LAYER OF REINFORCEMENT SHALL BE PRE-TENSIONED TO REMOVE SLACK BEFORE PLACEMENT OF BACKFILL. BEFORE STARTING WORK, THE CONTRACTOR SHALL DEMONSTRATE TO THE ENGINEER THE METHOD PROPOSED FOR PRE-TENSIONING THE REINFORCEMENT. COMPACTION LIFT THICKNESS SHALL A MAXIMUM OF 9 INCHES. IF THE COMPACTED SURFACE OF A LAYER IS TOO SMOOTH TO BOND WITH SUCCEEDING LAYERS, LOOSEN THE SURFACE BY HARROWING OR OTHER APPROVED METHOD BEFORE CONTINUING THE WORK. ANY EMBANKMENT FILLS PLACED BEHIND THE REINFORCED SHALL BE PLACED AND COMPACTED PRIOR TO PLACING THE NEXT REINFORCED BACKFILL LIFT. COMPACTION SHALL BE ACCOMPLISHED WITHOUT DISTURBANCE OR DISTORTION OF REINFORCING GEOGRIDS.

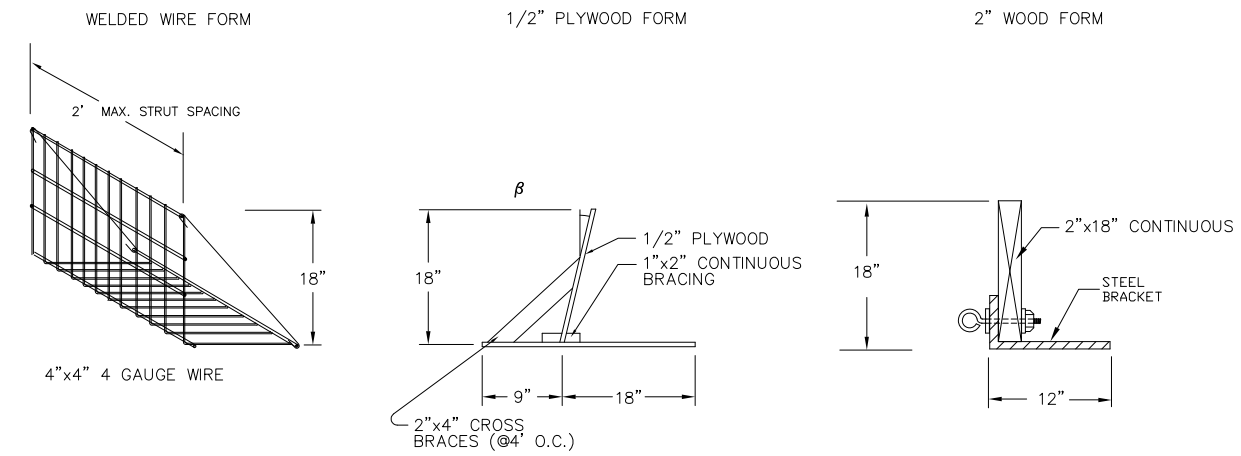

WRAP FORM DETAILS
(FACE OPTIONS)
NTS

| DATE | BY | DESCRIPTION | DATE | BY | DESCRIPTION | DATE | BY | DESCRIPTION | DATE | BY | DESCRIPTION | DRAWN BY | CHKD BY | DATE |
|------|----|-------------|------|----|-------------|------|----|-------------|------|----|-------------|----------|---------|------|
| | | | | | | | | | | | | | | |

TenCate MIRAFI

365 SOUTH HOLLAND DRIVE
PENDERGRASS, GA 30567

INSERT PROJECT NAME HERE
REINFORCED STEEPENED SLOPE
LOCALE, STATE